

Tools Required:
 3mm hex key
 4mm hex key
 5mm hex key
 8mm hex key
 Special tool (provided)

Protection Class: IP 65

Weight: 132 lbs.

Notice to Installer for 84 122:

- See page 3 for specific product safety warnings.
Luminaire is rated for direct burial installations.
- Wifi AP/router is not included (by others)
- Consult structural engineer and local codes for burial and foundation size and specs.
- Proper drainage below and around the buried portion of the luminaire **MUST** be provided. Failure to do so may void warranty.
- Wet location listing does not imply suitability for exposure to standing water for long periods of time.
- Fixture may be damaged if connected to conduit systems that contain water - Article 300-5G of the National Electric Code requires that "Conduits or raceways through which moisture may contact energized live parts shall be sealed or plugged at either or both ends."
- LEDs are high-quality electronic components! Please avoid touching the light output opening of the LED directly during installation.
- Customer WiFi module must be connected before installation of head. See page 2 for WiFi installation instructions.
- WiFi antenna provided with (4) coaxial cables with type N connectors for connection to WiFi router (by others).
- Important: Coaxial/network cable and power wires must be run in separate conduits to prevent interference.

84 122 installation:

- NOTE: AP/router (by others) must be connected into the WiFi segment before installation of head.**
NOTE: SIZE OF THE FOUNDATION REQUIRED TO SET THE UNIT IN CONCRETE MUST BE DETERMINED AT SITE BY STRUCTURAL ENGINEER.
- Fix ground plate to pole per (Figure 1).
- Pull supply wiring to a length where splices can be made through the lower access door. Communication/network cable must be pulled to upper WiFi access door.
- Route supply wiring through the mounting base and install pole (Figure 1, Figure 2) Use special tool provided to unlock the access door lock and remove access door.
- Route the luminaire wiring to the hand hold for connections.
- Continue to WiFi segment installation (Page 2).

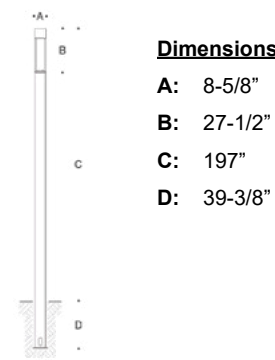

Dimensions
A: 8-5/8"
B: 27-1/2"
C: 197"
D: 39-3/8"

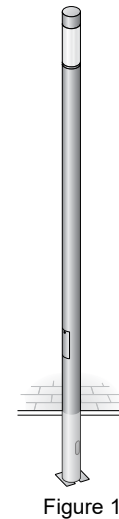
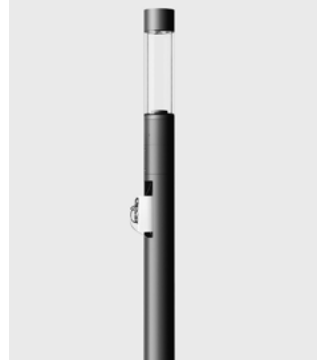

Figure 1

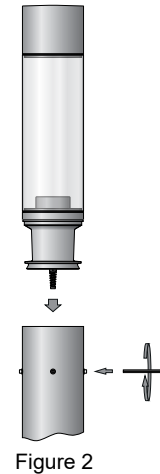

Figure 2

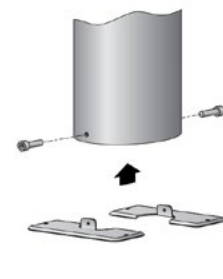

Figure 3

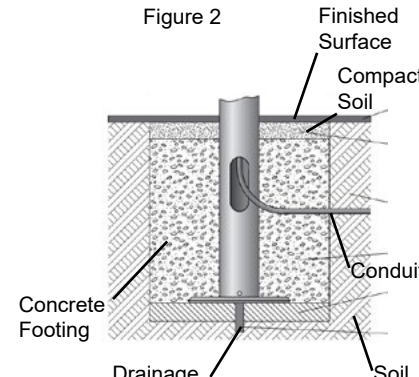

Figure 4

NOTE: Consult engineer and local codes for direct burial specification.

Relamping/Maintenance
 Clean luminaire regularly with solvent-free cleansers from dirt and debris. Do not use high pressure cleaners.

Lamp: 47.7W LED

Accessories
 Please refer to the appropriate accessory installation sheet for further instruction when applicable.

Replacement Parts	
Description	Part No
LED Driver (120-277V)	(X1) 76132-02
LED Module (2700K)	(X1) LED-0501/827
LED Module (3000K)	(X1) LED-0501/830
LED Module (3500K)	(X1) LED-0501/835
LED Module (4000K)	(X1) LED-0501/840

In the interest of product improvement, BEGA reserves the right to make technical changes without notice.

Tools Required:
 3mm hex key
 4mm hex key
 5mm hex key
 8mm hex key
 Special tool (provided)

Protection Class: IP 65

Weight: 132 lbs.

84 122 WiFi segment installation:

- Disassemble the WiFi segment before mounting to the luminaire pole.
- Loosen the (4) 3mm hex screws to remove antenna cover plates, remove the WiFi access door shown in (Figure 1), by using the special tool provided.
- Unscrew the (2) 4mm hex screws to separate upper and lower segments shown in (Figure 2).
- Insert and align the clamp ring into luminaire pole (Figure 3), so that the device bracket and wifi access door is facing the (2) lower splicing access doors located on the luminaire pole.
- Place the lower segment back over the WiFi antenna and clamp ring, then twist the lower segment until the WiFi access door aligns with device bracket sliding direction.
- Place the upper segment over the WiFi antenna and screw into place using (2) 4mm hexagon socket screws.
- Fasten the customer's WiFi router/AP to the device bracket using screws (provided) or other suitable material.
- Connect the WiFi antenna cables to the router/AP.
- See (page 3) for fixture wiring diagrams.
- See (Page 1) for fixture head installation.

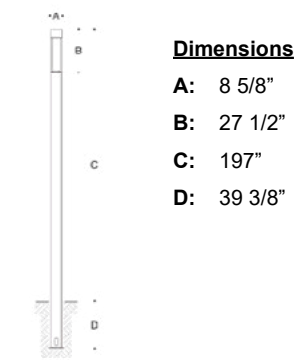

Dimensions
A: 8 5/8"
B: 27 1/2"
C: 197"
D: 39 3/8"

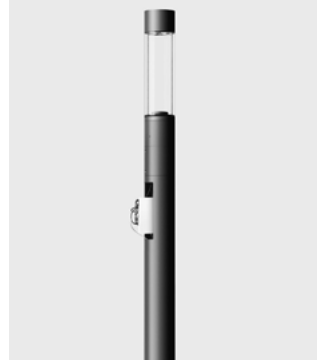

Figure 1

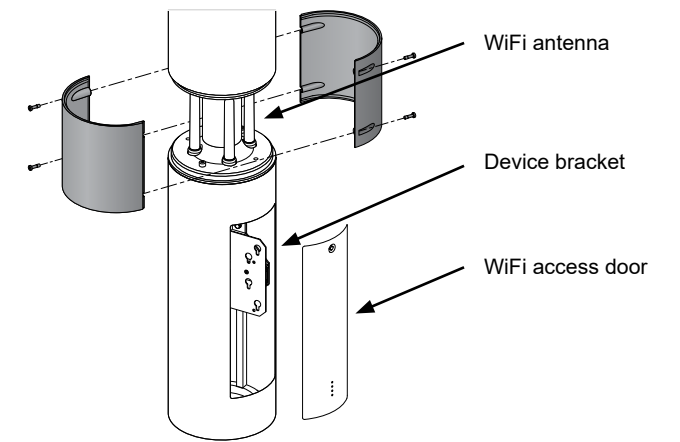

Figure 2

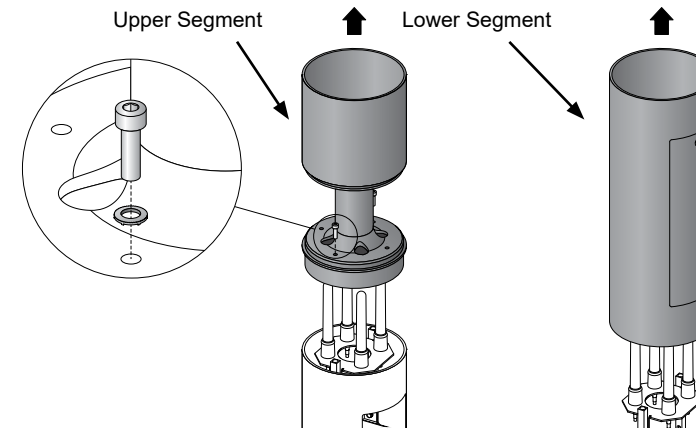
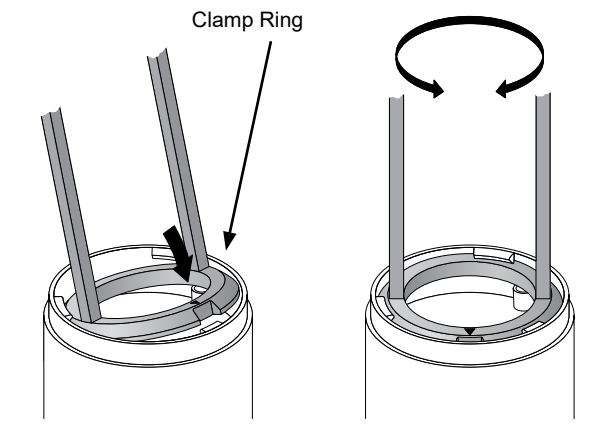

Figure 3



Relamping/Maintenance
 Clean luminaire regularly with solvent-free cleansers from dirt and debris. Do not use high pressure cleaners.

Lamp: 47.7W LED

Accessories
 Please refer to the appropriate accessory installation sheet for further instruction when applicable.

Replacement Parts	
Description	Part No
LED Driver (120-277V)	(X1) 76132-02
LED Module (2700K)	(X1) LED-0501/827
LED Module (3000K)	(X1) LED-0501/830
LED Module (3500K)	(X1) LED-0501/835
LED Module (4000K)	(X1) LED-0501/840

In the interest of product improvement, BEGA reserves the right to make technical changes without notice.

Tools Required:
 3mm hex key
 4mm hex key
 5mm hex key
 8mm hex key
 Special tool (provided)

Protection Class: IP 65

Weight: 132 lbs.



Dimensions
A: 8 5/8"
B: 27 1/2"
C: 197"
D: 39 3/8"



84 122 fixture head installation:

- Lead head wiring connections through pole then place and align fixture head on pole.
- Secure head onto pole by tightening (4) M5 hex key.
- Make supply wiring and luminaire wiring connections inside the luminaire at the lower access door:
 MAIN VOLTAGE SUPPLY WIRE TO BLACK LUMINAIRE WIRE
 NEUTRAL (COMMON) SUPPLY WIRE TO WHITE LUMINAIRE WIRE
 GREEN GROUND WIRE TO GREEN LUMINAIRE WIRE
 Dimming (if applicable):
 DIMMING CONTROL WIRE (+) TO POSITIVE DRIVER DIM CONTROL WIRE
 DIMMING CONTROL WIRE (-) TO NEGATIVE DRIVER DIM CONTROL WIRE.
- Once all segments are attached and connections have been made, attach and lock access door.

Figure 1

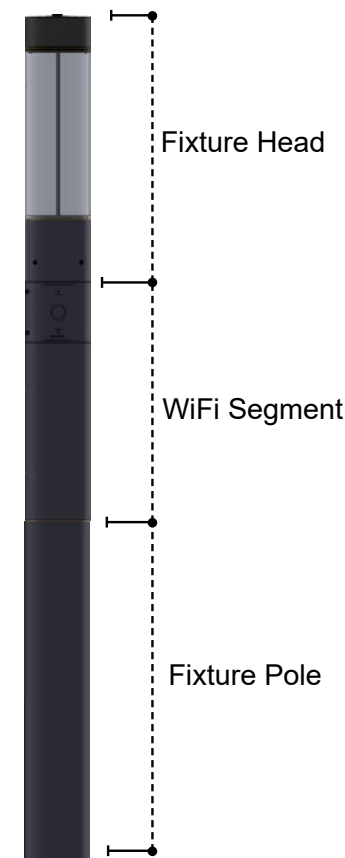
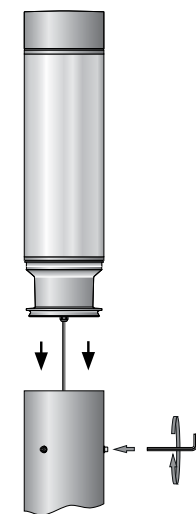

Relamping/Maintenance

Clean luminaire regularly with solvent-free cleansers from dirt and debris. Do not use high pressure cleaners.

Lamp: 47.7W LED

Accessories

Please refer to the appropriate accessory installation sheet for further instruction when applicable.

Replacement Parts

Description	Part No
LED Driver (120-277V)	(X1) 76132-02
LED Module (2700K)	(X1) LED-0501/827
LED Module (3000K)	(X1) LED-0501/830
LED Module (3500K)	(X1) LED-0501/835
LED Module (4000K)	(X1) LED-0501/840

In the interest of product improvement, BEGA reserves the right to make technical changes without notice.

Tools Required:
 3mm hex key
 4mm hex key
 5mm hex key
 8mm hex key
 Special tool (provided)

Protection Class: IP 65

Weight: 132 lbs.



Dimensions
A: 8-5/8"
B: 27-1/2"
C: 197"
D: 39-3/8"



FIXTURE HEAD

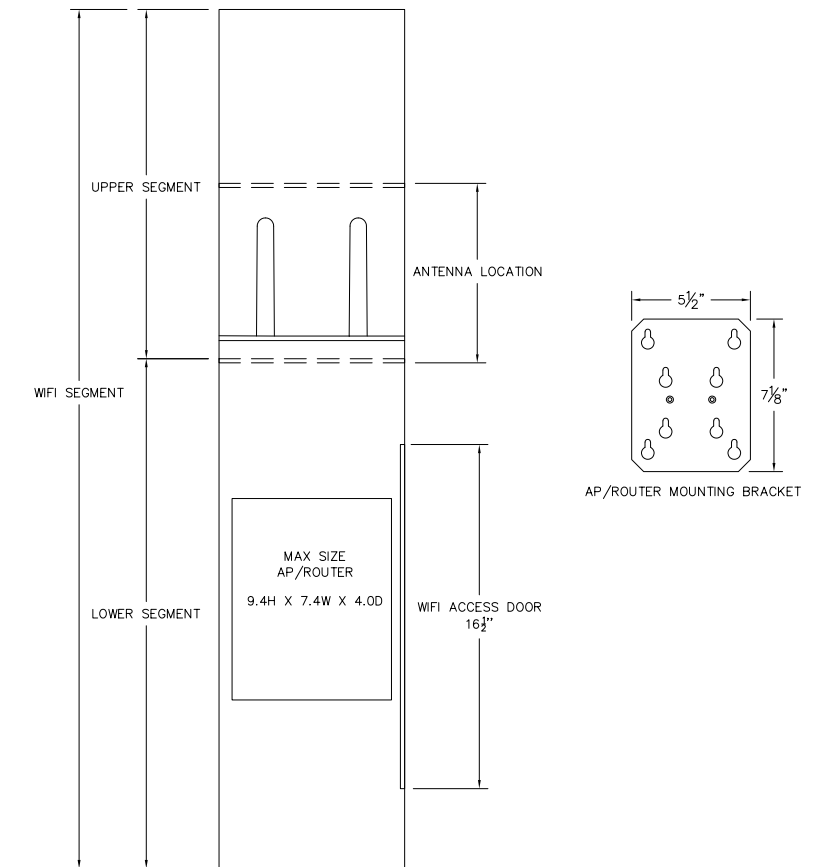
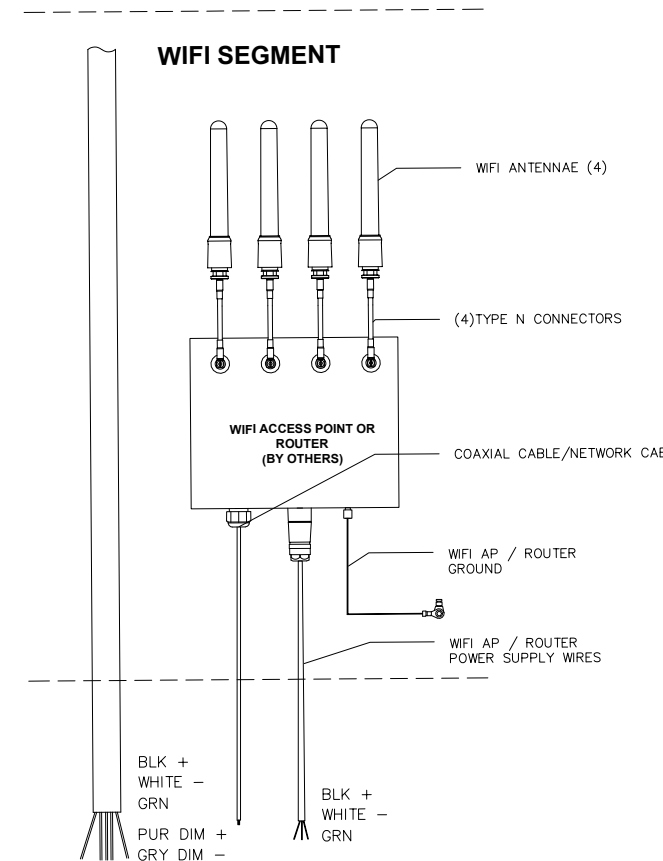

Relamping/Maintenance

Clean luminaire regularly with solvent-free cleansers from dirt and debris. Do not use high pressure cleaners.

Lamp: 47.7W LED

Accessories

Please refer to the appropriate accessory installation sheet for further instruction when applicable.

Replacement Parts

Description	Part No
LED Driver (120-277V)	(X1) 76132-02
LED Module (2700K)	(X1) LED-0501/827
LED Module (3000K)	(X1) LED-0501/830
LED Module (3500K)	(X1) LED-0501/835
LED Module (4000K)	(X1) LED-0501/840

In the interest of product improvement, BEGA reserves the right to make technical changes without notice.

Product Safety Warnings:

CAUTION- RISK OF FIRE. THIS PRODUCT MUST BE INSTALLED IN ACCORDANCE WITH THE APPLICABLE INSTALLATION CODE BY A PERSON FAMILIAR WITH THE CONSTRUCTION AND OPERATION OF THE PRODUCT AND THE HAZARDS INVOLVED.

SUITABLE FOR WET LOCATIONS.

MIN 90°C SUPPLY CONDUCTORS.

ATTENTION- RISQUE D'INCENDIE. CE PRODUIT DOIT ÊTRE INSTALLÉ SELON LE CODE D'INSTALLATION PERTINENT, PAR UNE PERSONNE QUI CONNAÎT BIEN LE PRODUIT ET SON FONCTIONNEMENT AINSI QUE LES RISQUES INHÉRENTS.

CONVIENT AUX EMPLACEMENTS MOUILLÉS.

LES FILS D'ALIMENTATION 90°C MIN.
