

NOTE:

- LUMINAIRE # 50 627 – SEE SPECIFICATIONS

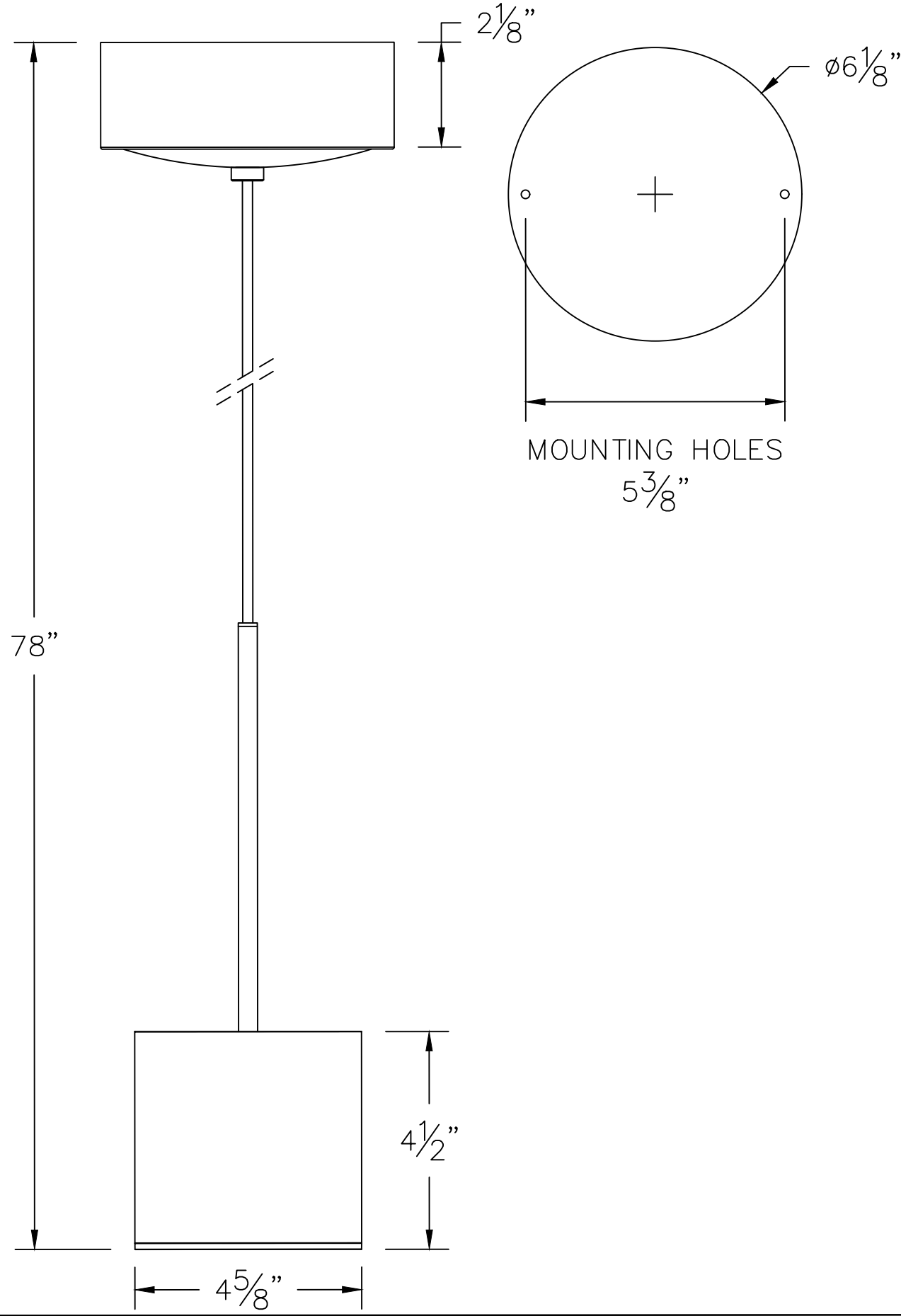

**SUBMITTAL APPROVAL**

APPROVED BY: \_\_\_\_\_ DATE: \_\_\_\_\_

SIGNED: \_\_\_\_\_

REV.	DATE	DESCRIPTION

CAT NO.: 50627\_BEGA\_SUBMITTAL

PROJECT: \_\_\_\_\_

LOCATION: \_\_\_\_\_

DRAWN: SBIELE DATE: 8/6/2020 FILE NAME: 50627\_BEGA\_SUBMITTAL.DXF

**BEGA**

1000 Bega Way  
Carpinteria, CA 93013  
(805) 684-0533

This print contains confidential information which is the property of BEGA U.S. By accepting this information, the borrower agrees that it will not be used for any other purpose other than that which is was loaned.