

Tools Required:

- Phillips medium flat head screw driver
- T20 TORX Head

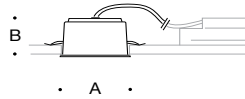

Dimensions

- A:** 5 1/2"
- B:** 3 1/2"



Overview:

- LED Watts: 8.1W
- System Watts: 9.5W
- Controllability: 0-10V Dimming down to 0.1%

Notice to Installer:

1. See page 4 for specific product safety warnings.
2. Luminaire is Non-IC rated. Insulation must be at least 3" from luminaire.
3. Luminaire not suitable for poured concrete construction.
4. Minimum ceiling clearance is 7" to fit ceiling box. Minimum ceiling thickness 1/4", maximum ceiling thickness is 1".
5. A recessed opening of 5-1/8" is required.
6. CEILINGBOX provided.
7. Integral LED module and ceiling box with LED Driver included, see page 2 for details.
8. LEDs are high-quality electronic components! Please avoid touching the light output opening of the LED directly during installation.

CEILINGBOX Installation:

1. Fixture is connected to ceilingbox via quick-disconnect. Disconnect fixture and ceilingbox.
2. Unscrew (2) 4mm TORX head screws to open ceiling box.
3. Bring supply wiring into ceiling box via strain relief bushing and make connections from supply wires to driver wires:
 MAIN VOLTAGE SUPPLY WIRE TO BLACK DRIVER WIRE(S);
 NEUTRAL (COMMON SUPPLY WIRE TO WHITE DRIVER WIRE(S);
 GREEN GROUND WIRE TO GREEN DRIVER WIRE(S).
 Dimming (0-10V, if applicable):
 DIMMING CONTROL WIRE (+) TO POSITIVE DRIVER DIM CONTROL WIRE
 DIMMING CONTROL WIRE (-) TO NEGATIVE DRIVER DIM CONTROL WIRE
4. Tighten (2) flat-head screws on strain relief bushing. Replace and tighten (2) 4mm TORX head screws to close ceiling box.
5. Push the ceiling box through the ceiling cut-out. The ceiling box will rest on ceiling panels or other ceiling construction material.
6. See page 3 for luminaire installation.

Note: Minimum ceiling clearance of 7" is required to fit ceiling box.

Figure 1:

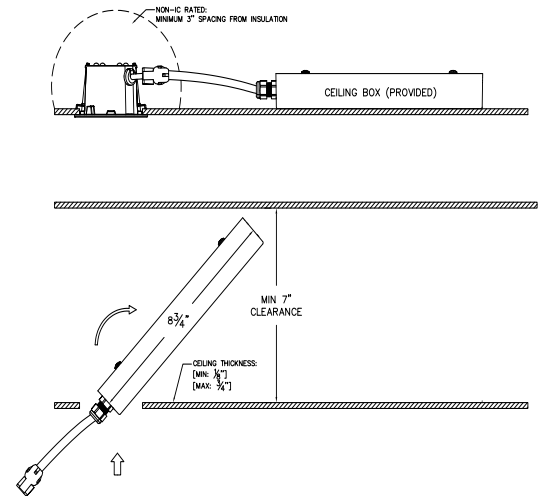

Accessories

Please refer to the appropriate accessory installation sheet for further instruction when applicable.

Maintenance:

Clean regularly with solvent-free cleaner removing dirt and debris. Do not use high pressure cleaners.

Replacement Parts

See label inside of fixture for LED replacement part number.

Consult factory for all other replacement components.

Tools Required:

Phillips medium flat head screw driver
T20 TORX Head

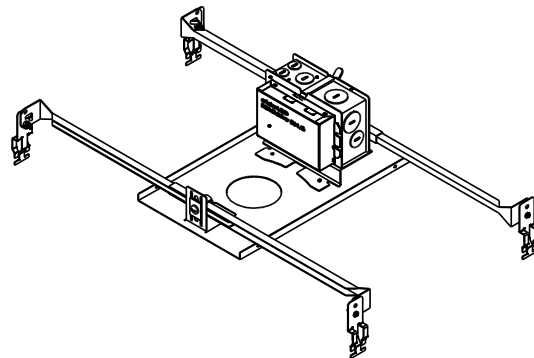

Overview: Ceiling Pan

Rating: Non-IC
 Ceiling Thickness: 1/8" Min - 3/4" Max
 Min Ceiling Clearance: 4 5/8"
 Ceiling Cutout: 5 1/8"
 Driver Location: Ceiling Pan
 Controllability: 0-10V dimmable down to 0.1%

Optional Ceiling Pan:

Notice to Installer:

1. See page 3 for specific product safety warnings.
2. Luminaire is non-IC rated. Insulation must be at least 3" from luminaire housing.
3. Minimum ceiling clearance is 4 5/8".
4. Ceiling thickness must be between 1/8" and 3/4".
5. Ceiling cut out is 5 1/8"
6. Driver (included) located on ceiling pan (Figure 1)

Installation: Suspended ceiling

1. Attach ceiling pan to T-bar using (4) (included) snap-on brackets.
2. Level rough-in kit so bottom of pan will sit on top of ceiling material.
3. Bring supply wiring in to junction box and make connections from supply wires to driver wires:

MAIN VOLTAGE SUPPLY WIRE TO BLACK BALLAST WIRE(S);
 NEUTRAL (COMMON SUPPLY WIRE TO WHITE BALLAST WIRE(S);
 GREEN GROUND WIRE TO GREEN BALLAST WIRE(S).

Dimming (if applicable):

DIMMING CONTROL WIRE (+) TO POSITIVE DRIVER DIM CONTROL WIRE
 DIMMING CONTROL WIRE (-) TO NEGATIVE DRIVER DIM CONTROL WIRE

Accessories

Please refer to the appropriate accessory installation sheet for further instruction when applicable.

Maintenance:

Clean regularly with solvent-free cleaner removing dirt and debris. Do not use high pressure cleaners.

Replacement Parts

See label inside of fixture for LED replacement part number.

Consult factory for all other replacement components.

Tools Required:

- Phillips medium flat head screw driver
- T20 TORX Head

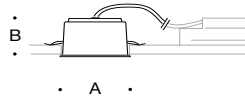

Dimensions

- A: 5 1/2"
- B: 3 1/2"



Overview:

- LED Watts: 8.1W
- System Watts: 9.5W
- Controllability: 0-10V Dimming down to 0.1%

50 395 Installation:

1. The recessed housing is installed by pushing the 2 tabs upward and pushing housing through ceiling cut out. A recessed opening of 5-1/8" is required.
2. Push rough-in housing into opening in ceiling. Rough-in housing is held into place with (2) spring clips. If ceiling is less than 1/4" thick, it must be reinforced for proper installation.
3. Connect quick-disconnect and tethered aircraft cable between the ceiling box and luminaire housing.
4. Press tabs together inside luminaire housing and push up into the rough-in housing. Release the tabs and ensure the luminaire housing is secured (Figure 1).
5. Place the reflector onto the trim ring and push both up into the luminaire housing. Twist the trim ring clockwise to secure into place. (Figure 2)

Figure 1:

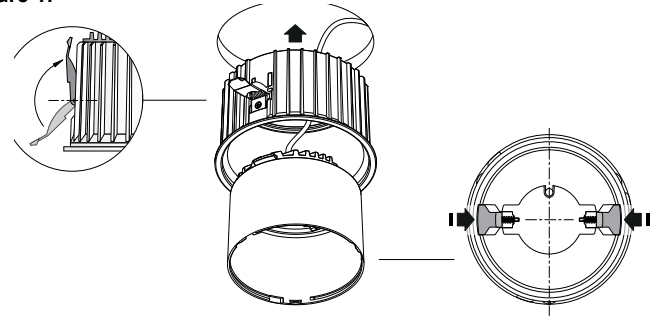
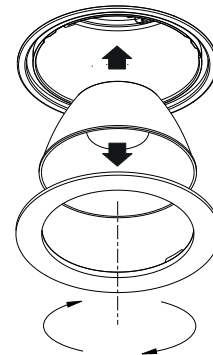

Figure 2:



Accessories

Please refer to the appropriate accessory installation sheet for further instruction when applicable.

Maintenance:

Clean regularly with solvent-free cleaner removing dirt and debris. Do not use high pressure cleaners.

Replacement Parts

See label inside of fixture for LED replacement part number.

Consult factory for all other replacement components.

Product Safety Warnings:

THIS PRODUCT MUST BE INSTALLED IN ACCORDANCE WITH THE APPLICABLE INSTALLATION CODE BY A PERSON FAMILIAR WITH THE CONSTRUCTION AND OPERATION OF THE PRODUCT AND THE HAZARDS INVOLVED. SUITABLE FOR WET LOCATIONS. MIN 90°C SUPPLY CONDUCTORS.

CE PRODUIT DOIT ÊTRE INSTALLÉ SELON LE CODE D'INSTALLATION PERTINENT, PAR UNE PERSONNE QUI CONNAÎT BIEN LE PRODUIT ET SON FONCTIONNEMENT AINSI QUE LES RISQUES INHÉRENTS. CONVIENT AUX EMPLACEMENTS MOUILLÉS.

LES FILS D'ALIMENTATION 90°C MIN.