

NOTES:  
 1. LUMINAIRE # 33 429 - SEE SPECIFICATIONS

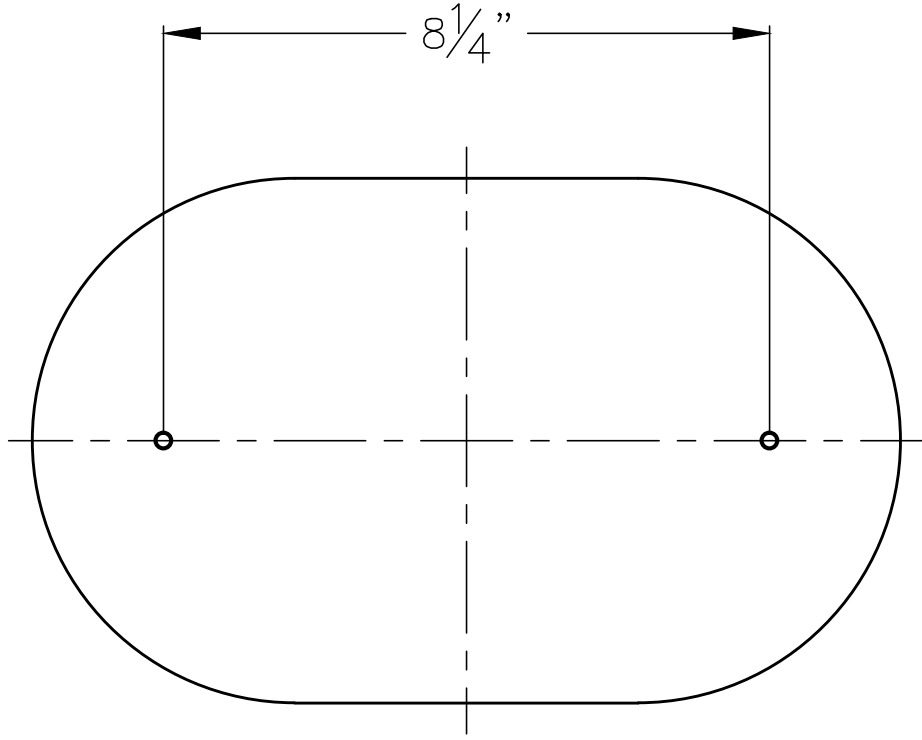

MOUNTING DETAIL

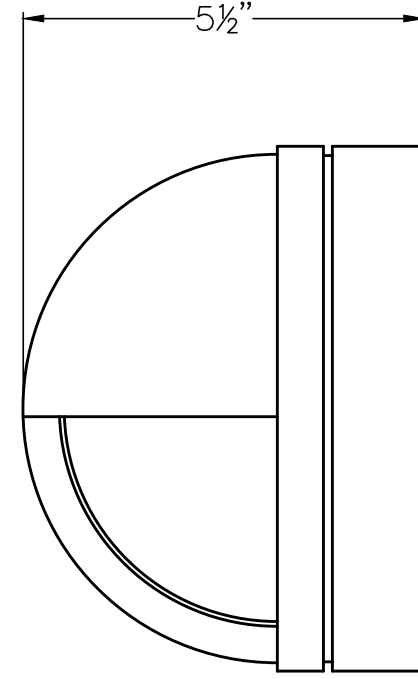
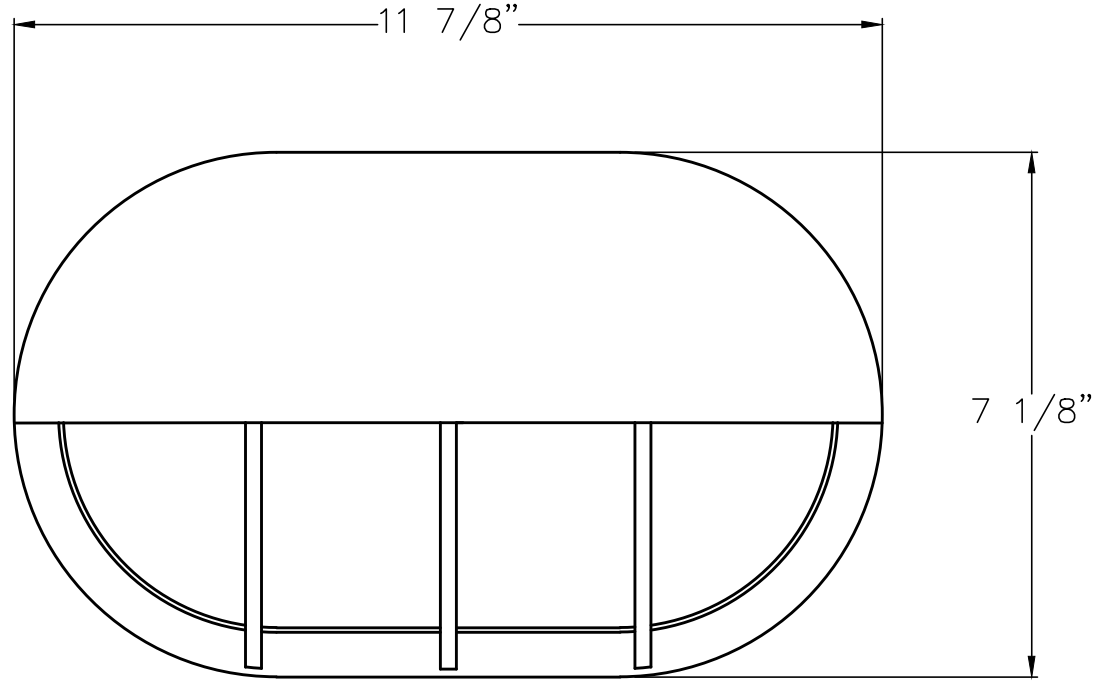

**TYPE:** \_\_\_\_\_

**SUBMITTAL APPROVAL**

APPROVED BY: \_\_\_\_\_ DATE: \_\_\_\_\_  
 SIGNED: \_\_\_\_\_

REV.	DATE	DESCRIPTION

CAT NO.: 33 429

PROJECT: -

LOCATION: -

DRAWN: AV DATE: 7/20/15 File Name: 33429.dxf

**BEGA**

1000 Bega Way  
 Carpinteria, Ca. 93013  
 (805) 684-0533

This print contains confidential information which is the property of BEGA U.S. By acceptance this information, the borrower agrees that it will not be used for any other purpose other than that which is was loaned.