

NOTE: LUMINAIRE # 31 327 - SEE SPECIFICATIONS

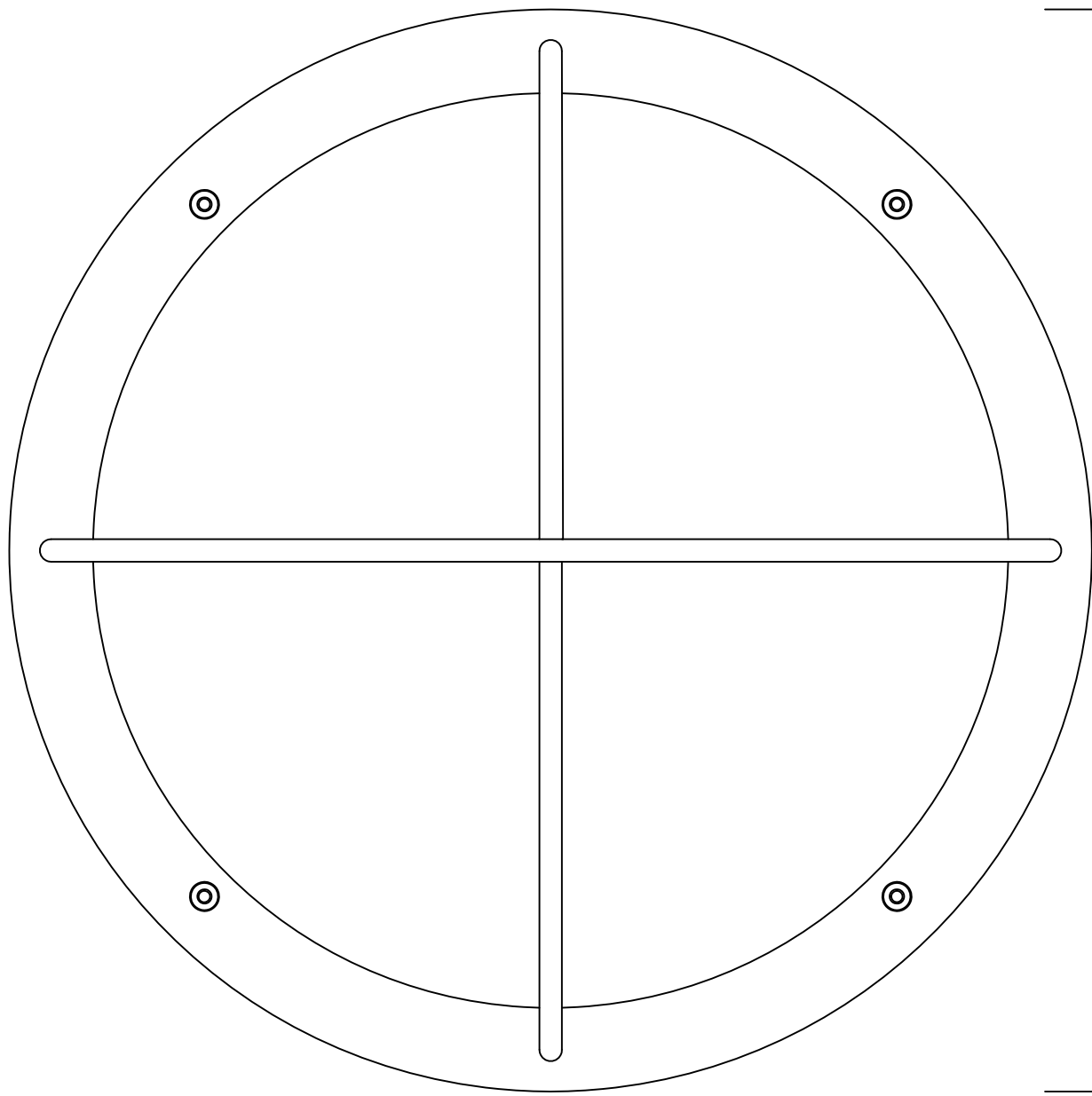

8 5/8"

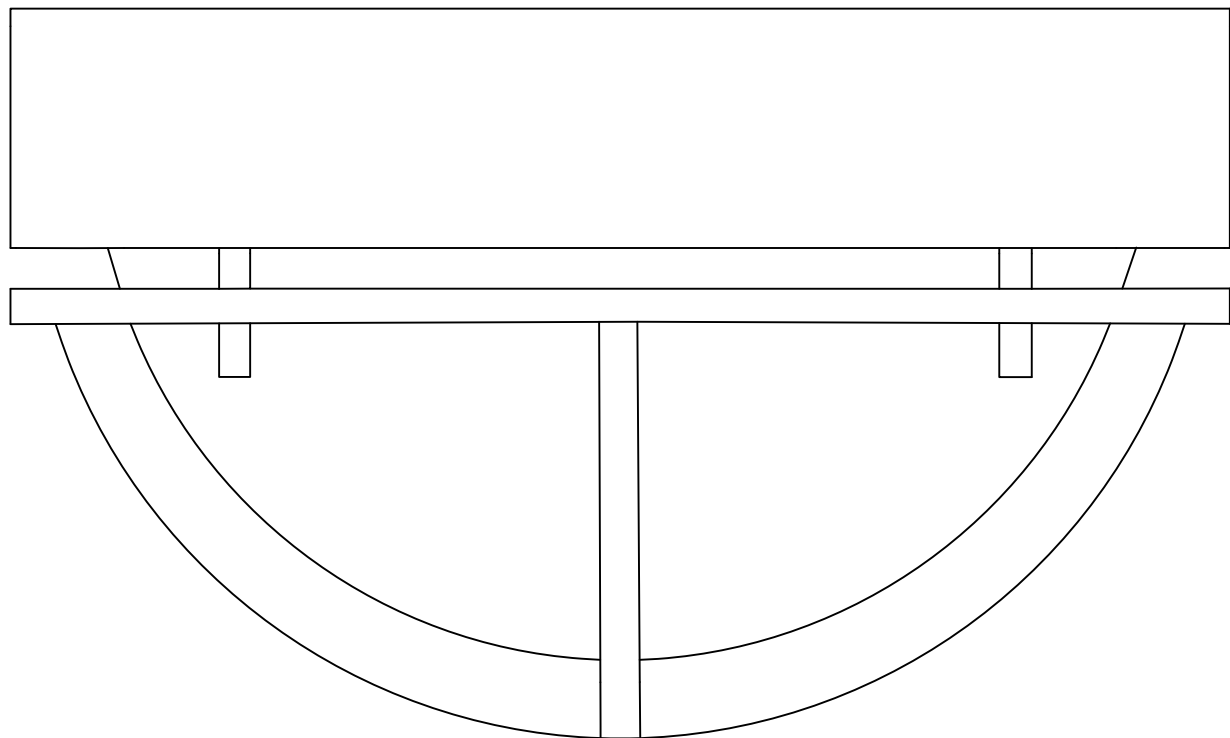

5 1/8"

TYPE: _____

SUBMITTAL APPROVAL

APPROVED BY: _____
 SIGNED: _____ DATE: _____

CAT NO.: 31 327
 PROJECT: -
 LOCATION: -
 DRAWN: RA DATE: 7/18/2017 FILE NAME: 31327.dxf

BEGA
 1000 Bega Way
 Carpinteria, Ca. 93013
 (805) 684-0533

| REV. | DATE | DESCRIPTION |
|------|------|-------------|
| | | |

This print contains confidential information which is the property of BEGA U.S. By acceptance this information, the borrower agrees that it will not be used for any other purpose other than that which is was loaned.