

NOTE: LUMINAIRE # 24 826 – SEE SPECIFICATIONS

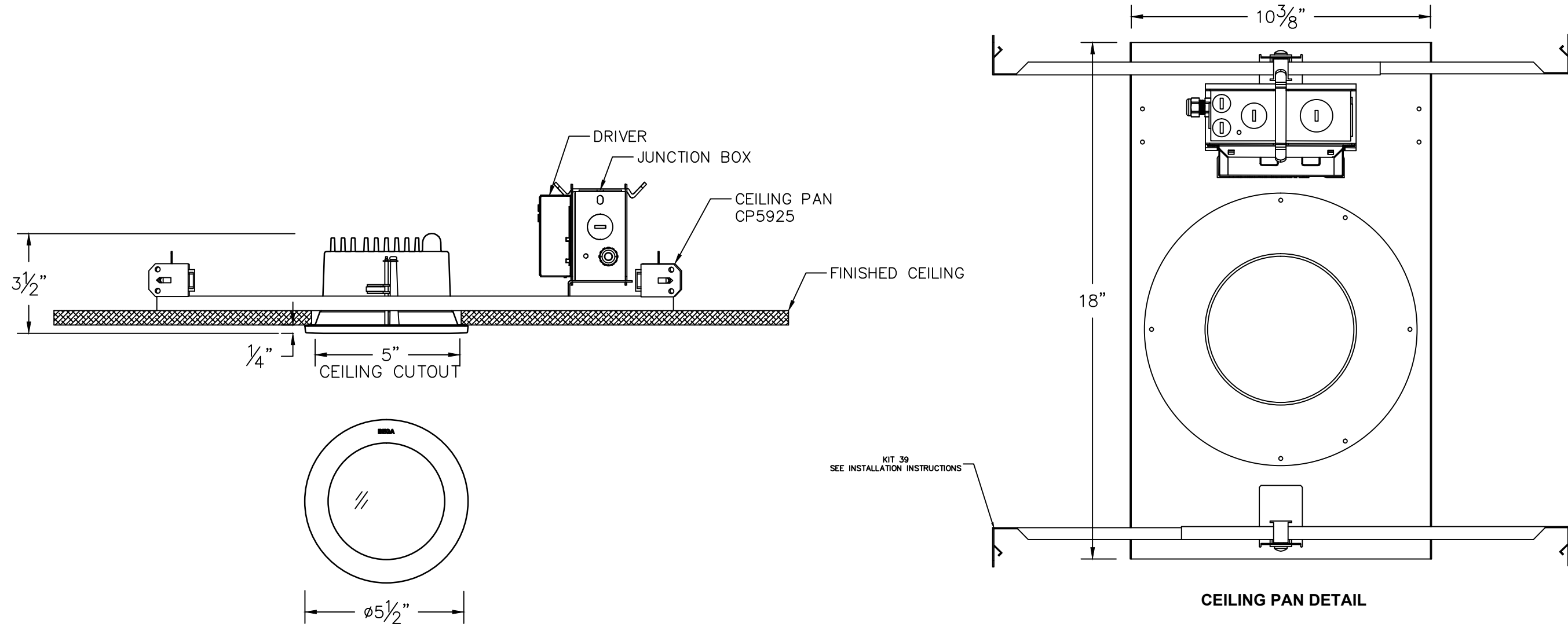

TYPE: _____

SUBMITTAL APPROVAL

APPROVED BY: _____ DATE: _____
 SIGNED: _____

| REV. | DATE | DESCRIPTION |
|------|------|-------------|
| | | |

CAT NO.: 24 826

PROJECT: -

LOCATION: -

DRAWN: RA

DATE: 1/18/2017

FILE NAME: 24826.dxf

BEGA

1000 Bega Way
 Carpinteria, Ca. 93013
 (805) 684-0533