

NOTES:  
 1. LUMINAIRE # 23 664 - SEE SPECIFICATIONS;

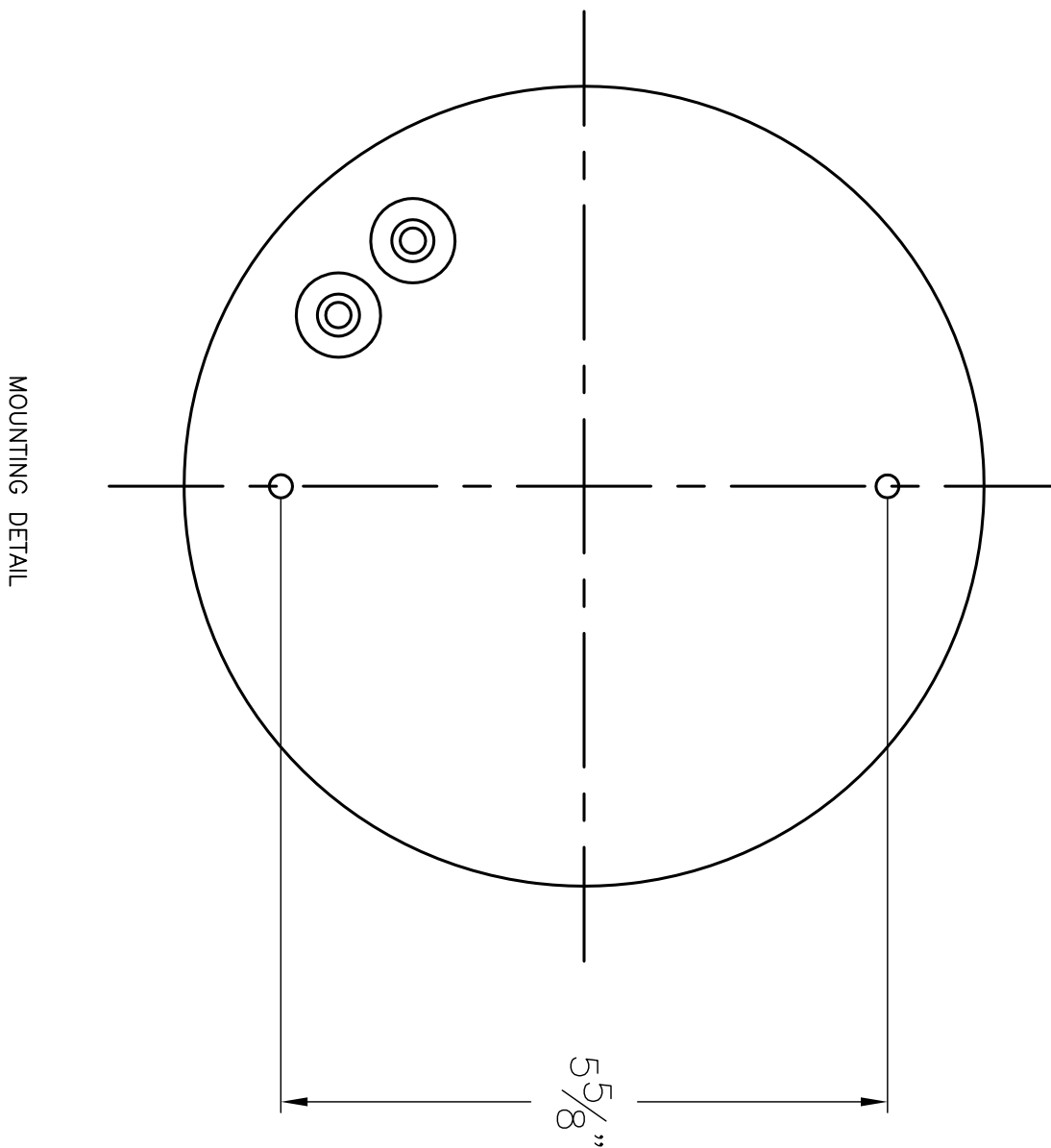
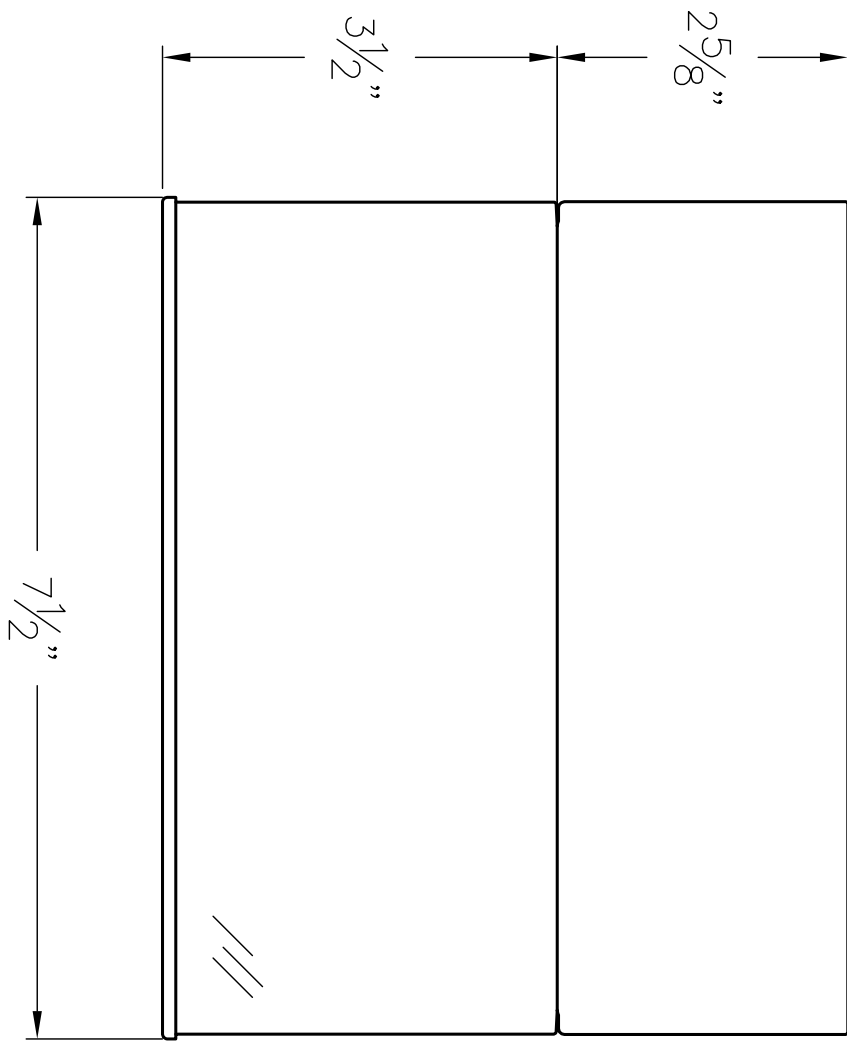

TYPE: \_\_\_\_\_

**SUBMITTAL APPROVAL**

APPROVED BY: \_\_\_\_\_

SIGNED: \_\_\_\_\_ DATE: \_\_\_\_\_

CAT NO.: 23 664

PROJECT: -

LOCATION: -

DRAWN: AV DATE: 11/21/14 File Name: 23664.DXF

**BEGA**

1000 Bega Way  
 Carpinteria, Ca. 93013  
 (805) 684-0533

REV.	DATE	DESCRIPTION

This print contains confidential information which is the property of BEGA U.S. By acceptance this information, the borrower agrees that it will not be used for any other purpose other than that which is was loaned.