

NOTE: LUMINAIRE # 22 649 — SEE SPECIFICATIONS

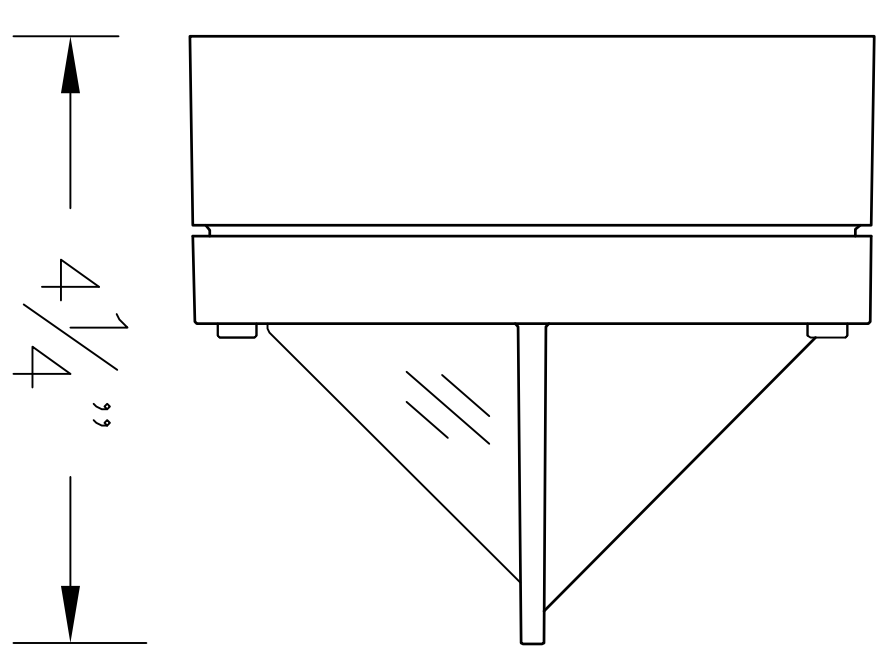
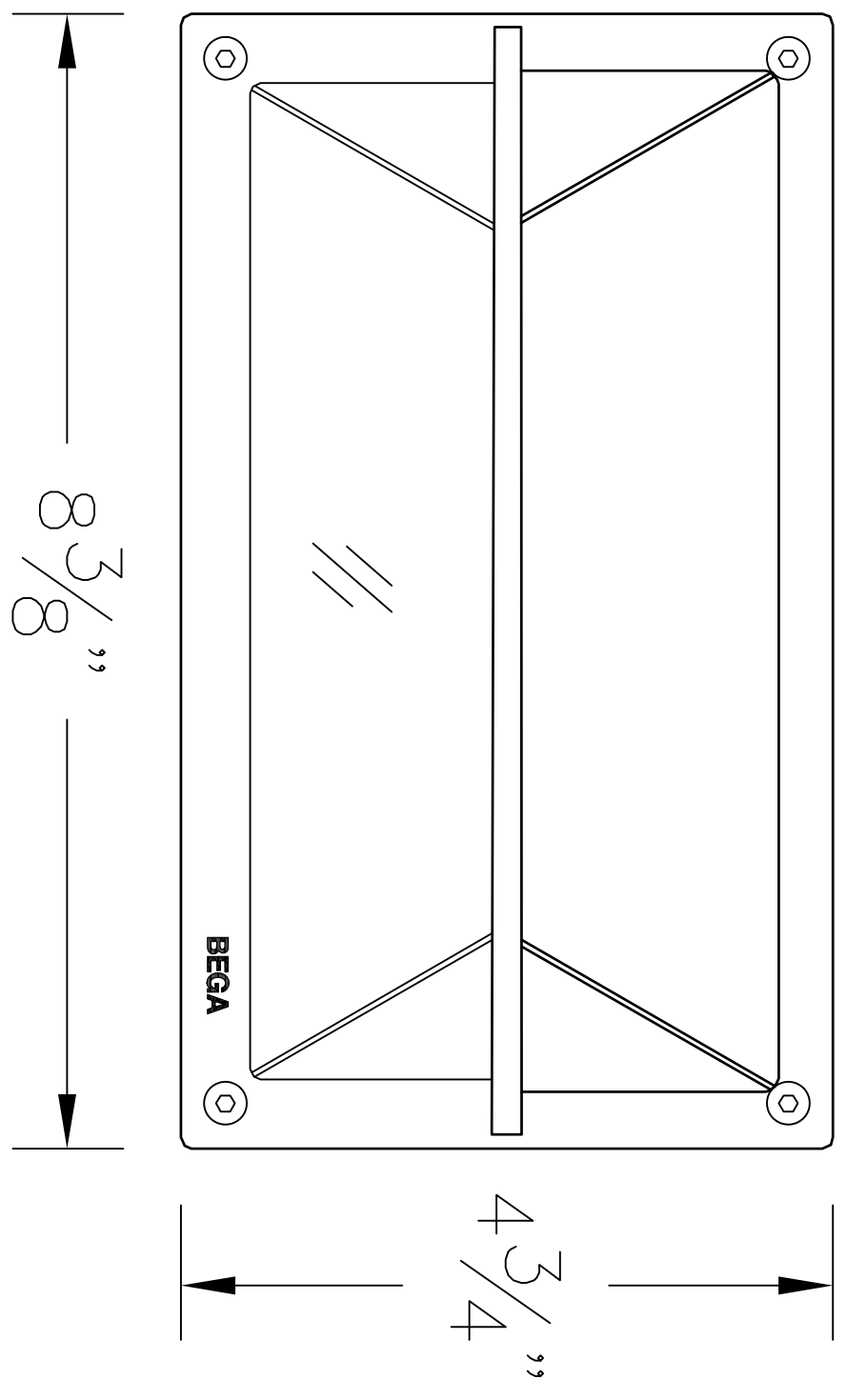

TYPE: _____

SUBMITTAL APPROVAL			CAT NO.: 22 649		BEGA
			PROJECT: -		
APPROVED BY: _____	LOCATION: -		DRAWN: RA		
SIGNED: _____	DATE: _____	DATE: 4/17/2018		FILE NAME: 22649.dxf	
REV.	DATE	DESCRIPTION			

This print contains confidential information which is the property of BEGA U.S. By acceptance this information, the borrower agrees that it will not be used for any other purpose other than that which is was loaned.